



Light curtains remove need for a safety gate leaving open access for loading. Also allows single operator operation with controls at the tipping side.



Fully open loading area with no gates for simple fast loading.



Fully welded construction with all cables and pipe work concealed where possible.



Pneumatic operation, no chance of hydraulic oil contamination.



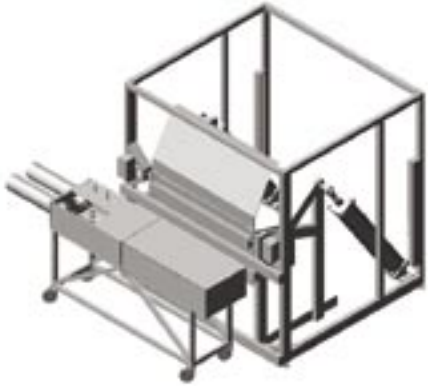

Hoist feeding stuffer exiting to the left.



Hoist feeding stuffer exiting to the right.



Hoist feeding one stuffer, exiting to the front.



Hoist feeding two stuffers, exiting to the front.

Custom hoppers can be designed to tip onto any machine or work surface.