





Information Screen controlling machine functions and reporting output and efficiency figures.



Emergency Stop buttons mounted on both sides.



Braked Castors, ensuring secure footing while working and easy movement when required.



Swan Ney Cable System, eliminating water ingress.



Chamber Sets come complete with Pistons and Donuts, making gaps as small as possible for the wettest of products.



Integrated Drip Tray to catch any falling product.



Water Resistant electrical cabinet.



Simple Tool-less Chamber size change.

## OPTIONS

### AWI Automatic Water Injection

Injects a fine spray of water into each chamber each cycle to allow easy movement of dry products such as pork.

### SSL Selectable Stroke Length

Allows shortening of piston strokes, to optimise shape.

### APH Automatic Piston Hold

Pausing the piston in its outward position, to allow further shaping of the product.



Available in all sizes from 75–200 mm  
EH version available for tube sizes up to 250 mm

## TECHNICAL INFORMATION

### Speed

The machine will cycle at over 1000 units per hour.  
Production speeds will depend on the product and the input and output flow to the machine.

### Weight

Approximately 800 kg

### Services

#### Compressed Air

80 psi or 5.5 BAR  
70 ft<sup>3</sup> or 200 litres per minute  
10 mm ID Air Supply Line Minimum

#### Electrical

230 V, Single phase, 5 amp supply

#### Packing Crate Dimensions

Length 2590 mm Width x 1160 mm x Height 1550 mm

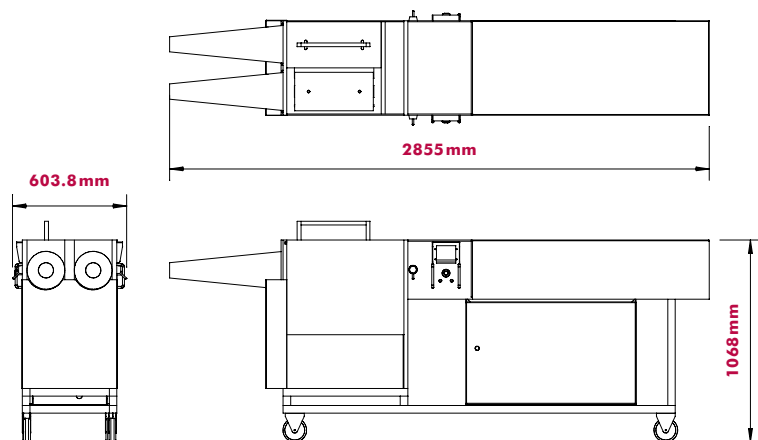
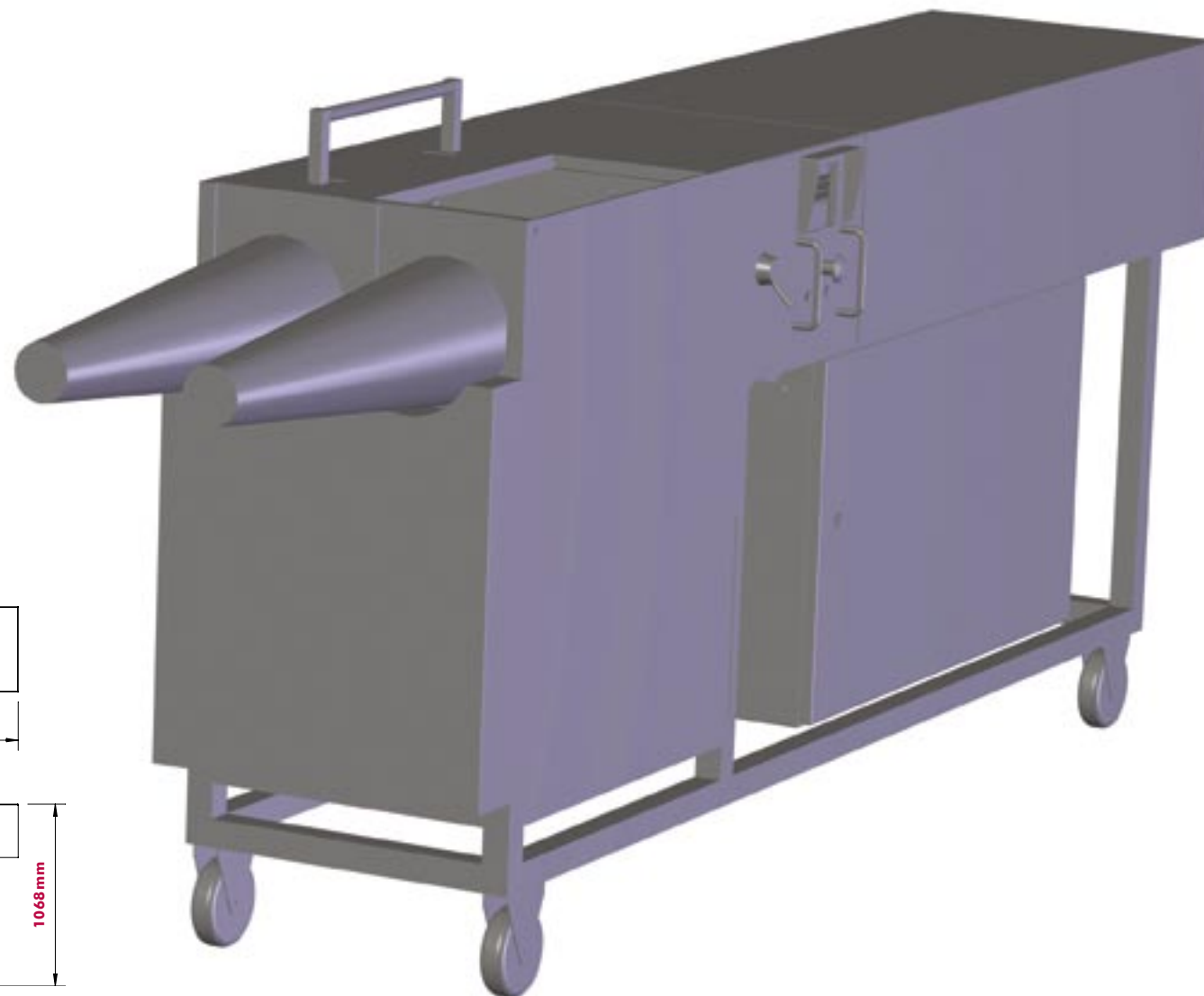

Please note: dimensions are subject to change without notice.



Can be used with our netting or casing tubes.



Spring steel fingers bolted on to ensure long life and easy replacement, if required.



The fingers have rounded ends to prevent casing damage and have dimples to hold the casing during stuffing.



All the accessories are permanently marked with their size for easy identification.



The chambers are fitted with fully welded rails enabling tool-less changes.



PXP Pistons are made from solid food grade nylon and drilled to prevent suction on the return strokes.

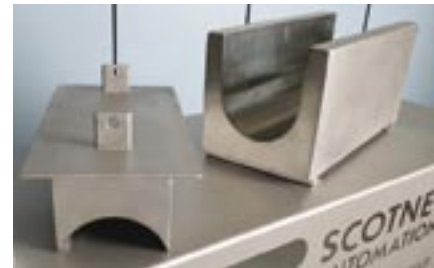

PXP Chamber and Top



When the chamber and top come together in the machine the product is formed into this perfect circle prior to stuffing.